

OLYMPUS[®]

Your Vision, Our Future

Polarizing Microscope

BX53-P

BX3 Series



UIS2
World-leading optics

Excellent Optics Render Polarized Light Images Sharper than Ever Before.

Olympus is proud to introduce the BX53-P, the new polarizing microscope with superb performance in polarized light. It's a breakthrough combination of UIS2 infinity-corrected optics and Olympus original optical-design. Olympus has also devised a new, extended line of compensators to make the BX53-P versatile enough to handle observation and measuring applications in virtually any field.

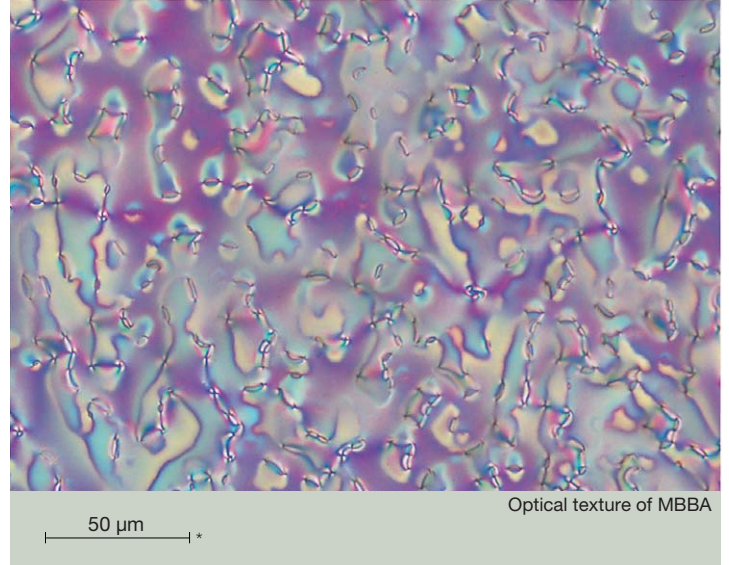
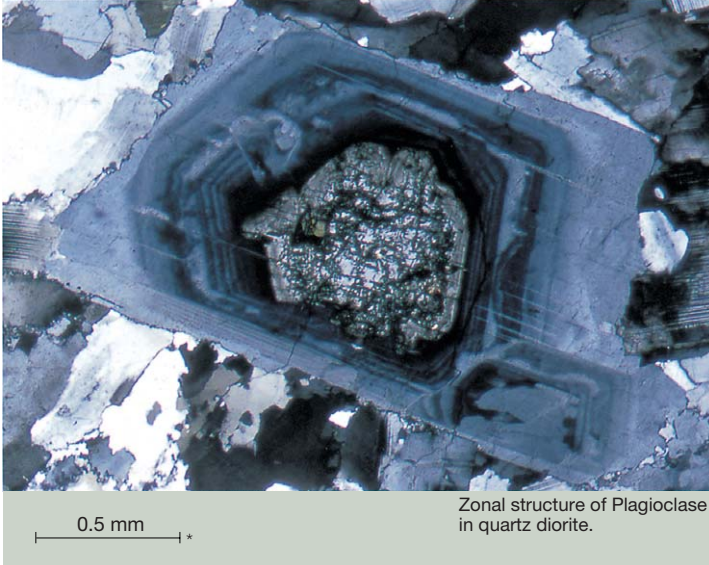

*Scales indicate actual size of samples

UIS2 Provides Outstanding System Expandability.

By maximizing the advantages of infinity correction, the UIS2 optical system prevents the deterioration of optical microscope performance and eliminates magnification factors, even when polarizing elements like analyzers, tint plates or compensators are introduced into the light path.

Maintaining the high level of system flexibility, the BX53-P also accepts intermediate attachments available for the BX3 Series system microscopes, as well as cameras and imaging systems.



BX53-P Orthoscopic Configuration



BX53-P Conoscopic/Orthoscopic Configuration

An upgrade in Polarization Characteristics.

Thanks to Olympus' sophisticated design and manufacturing technology, the ACHN-P and UPLFLN-P objectives reduce internal strain. BX3 polarizing microscope features high EF-value filters in polarizer and analyzer resulting in unmatched image contrast. To meet a diversity of research and application requirements, the universal UPLFLN-P series objectives have been designed to accommodate a wide range of observation methods, including Nomarski DIC and fluorescence microscopy, in addition to polarized light observation.

*The EF (extinction factor) is the brightness ratio between parallel and crossed pol-filters. The higher the EF value, the better the extinction.



UPLFLN-P Series



ACHN-P Series

UPLFLN-P Series

Item	NA	W.D.
UPLFLN 4XP	0.13	17.0 mm
UPLFLN 10XP	0.3	10.0 mm
UPLFLN 20XP	0.5	2.1 mm
UPLFLN 40XP	0.75	0.51 mm
UPLFLN 100XOP	1.3	0.2 mm

PLN-P

Item	NA	W.D.
PLN 4XP	0.1	18.5 mm

ACHN-P Series

Item	NA	W.D.
ACHN 10XP	0.25	6.0 mm
ACHN 20XP	0.40	3.0 mm
ACHN 40XP	0.65	0.45 mm
ACHN 100XOP	1.25	0.13 mm

*All UIS2 objectives and WHN eyepieces: lead-free eco-glass



①U-TP530 ②U-TP137 ③U-TAD ④U-CBR1 ⑤U-CBR2 ⑥U-CWE2 ⑦U-CSE ⑧U-CBE ⑨U-CTB

An Extensive Range of Compensators is Available.

Six different compensators are available for the BX53-P microscope, allowing measurement of various retardation levels, ranging from 0 to 20λ . For easier measurement, the direct readout method is featured.

Higher image contrast can be attained by using a Senarmont* or Brace-Koehler compensator to change the retardation level in the entire field of view.

* Used with monochromatic green filter, IF546 or IF550.

Measuring Range of Compensators

Compensator	Measurement Range	Applications
Thick Berek (U-CTB)	0-11,000 nm (20λ)	Measurement of High Retardation Level ($R^* > 3\lambda$), (crystals, macromolecules, fiber, etc.)
Berek (U-CBE)	0-1,640 nm (3λ)	Measurement of Retardation Level (crystals, macromolecules, living organisms, etc.)
Senarmont Compensator (U-CSE)	0-546 nm (1λ)	Measurement of Retardation Level (crystals, living organisms, etc.) Enhancement of Image Contrast (living organisms, etc.)
Brace-Koehler Compensator 1/10 λ (U-CBR1)	0-55 nm (1/10 λ)	Measurement of Low Retardation Level (living organisms, etc.)
Brace-Koehler Compensator 1/30 λ (U-CBE2)	0-20 nm (1/30 λ)	Enhancement of Image Contrast (living organisms, etc.)
Quartz Wedge (U-CWE2)	500-2,200 nm (4λ)	Approximate Measurement of Retardation Level (crystal, macromolecules, etc.)

*R= retardation level

For more accurate measurement, it is recommended that compensators (except U-CWE2) be used together with the interference filter 45-IF546.



①U-CPA ②U-P4RE ③U-AN360P-2 ④U-OPA ⑤U-POC-2

Outstanding Sharpness in Orthoscopic and Conoscopic Observations.

With a U-CPA conoscopic observation attachment, changeover between orthoscopic and cono-scopie observation is simple and quick. Focusing of conoscopic images is easy and accurate. Employing a Bertrand field stop makes it possible to obtain consistently sharp and clear conoscopic images.

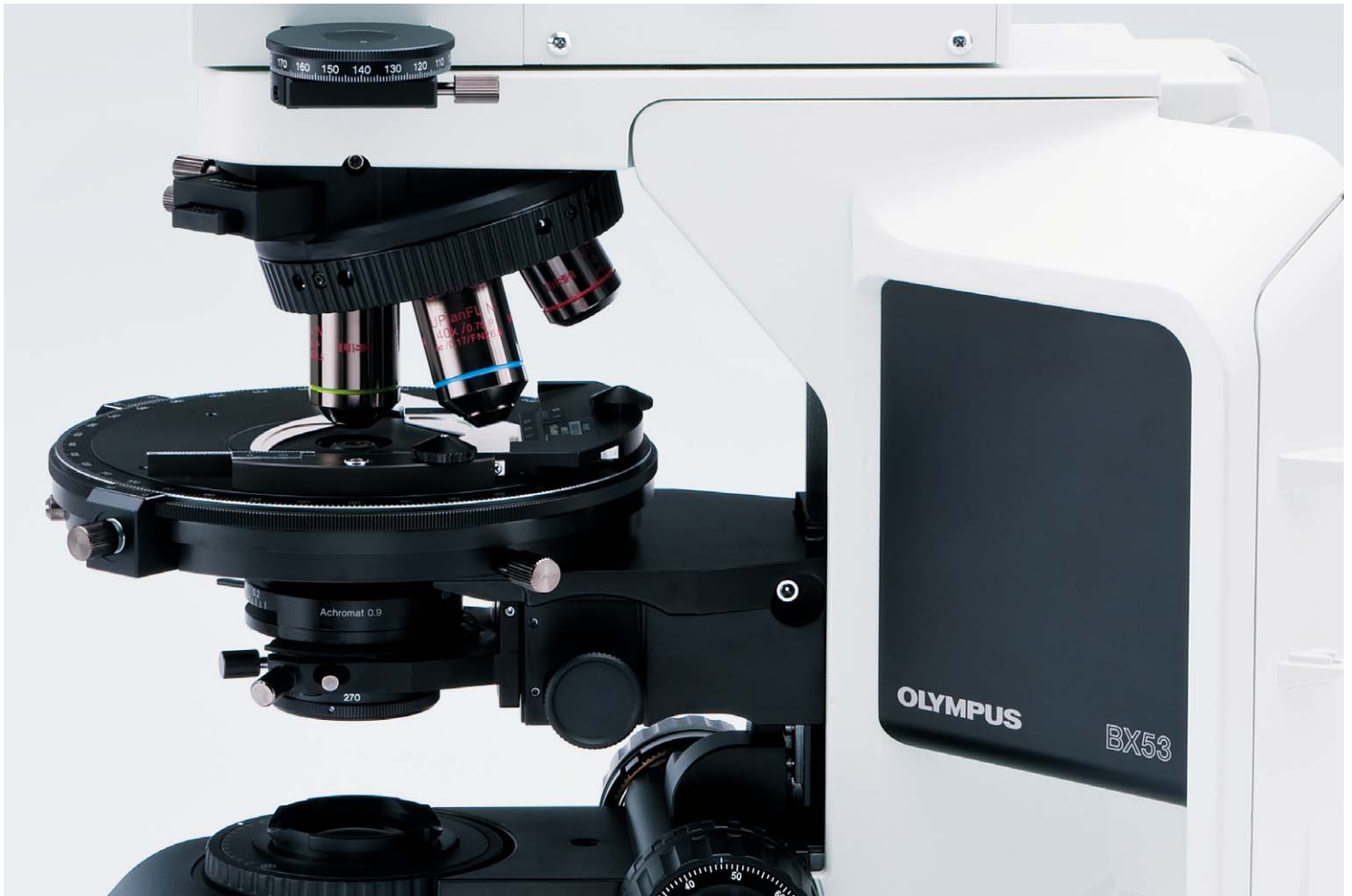

Enhanced Operational Ease and Outstanding Optical Performance.

- With the U-CPA conoscopic observation attachment, the changeover between orthoscopic and conoscopic observation methods is simple and quick — just slide the Bertrand lens control knob in or out.
- The circular rotatable stage has two centering knobs and allows smooth sample rotation. A settable click stop every 45 degrees enables accurate observation and measurement.
- Mounting an attachable cross-movement mechanical stage (U-FMP) onto the circular rotatable stage makes for improved observation efficiency. Interference between the mechanical stage and the objectives is eliminated, so that images of superb quality can be effortlessly observed with all objective magnification.
- The high intensity 12 V, 100 W halogen light source combined with the UIS2 optical system and its high transmittance result in exceptionally bright and sharp images.



U-FMP

BX53-P System Diagram

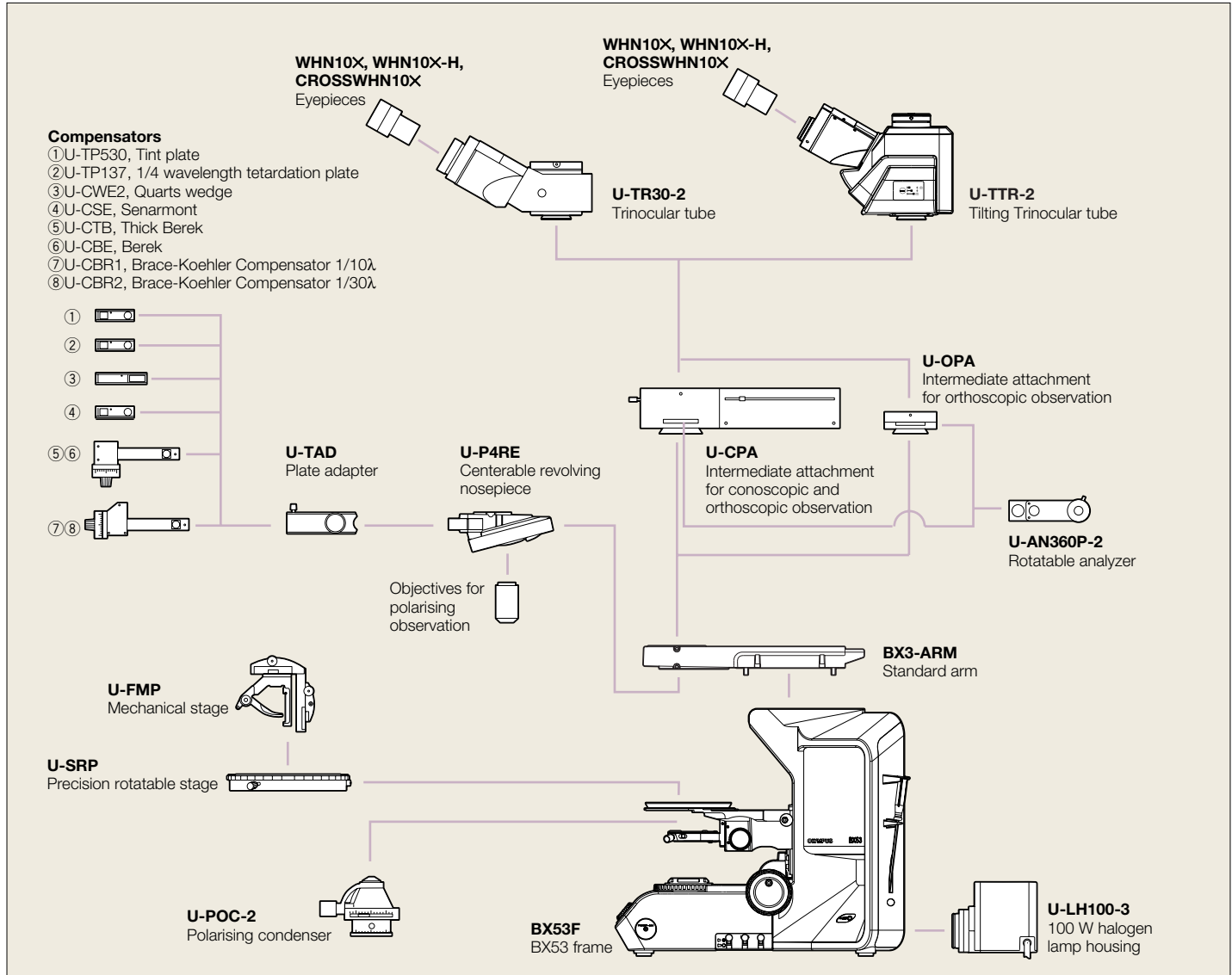

BX53-P Dimensions

(unit: mm)

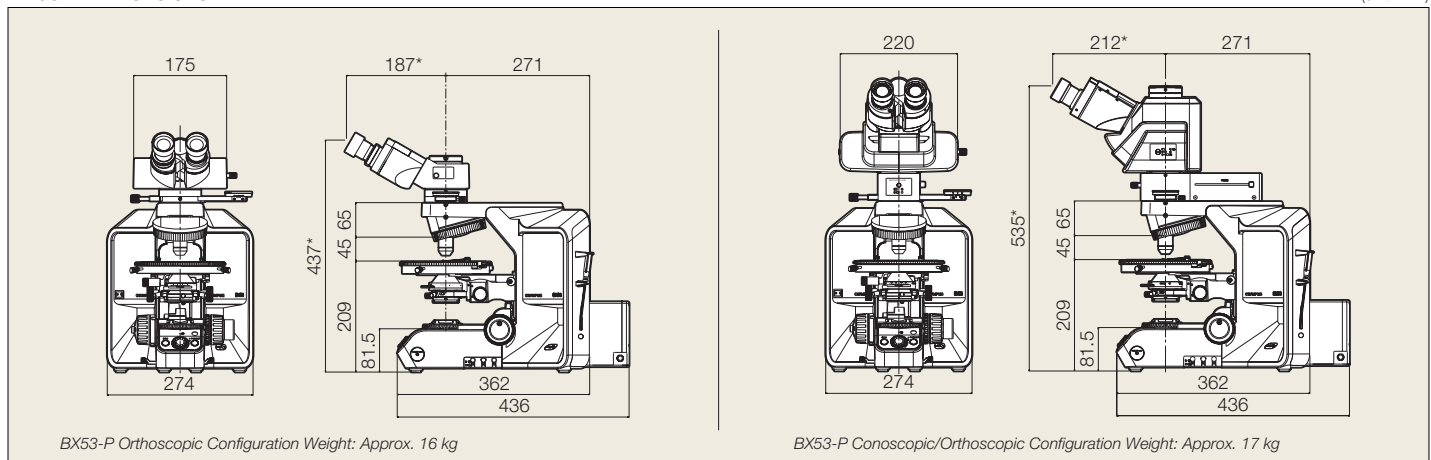

Power consumption: Approx. 140 W Note: The length marked with an asterisk (*) may vary according to the interpupillary distance setting. Distance for figure shown is 62 mm.

BX53-P Specifications

Item	Conoscopic and Orthoscopic Observation (U-CPA)	Orthoscopic Observation (U-OPA)
Polarized Light Intermediate Attachment (U-CPA or U-OPA)	FN	22
	Bertrand Lens	Focusable
	Bertrand Field Stop	ø3.4 mm Diameter (fixed)
	Engage or disengage Bertrand lens changeover between orthoscopic and conoscopic observation	Position of slider ● in Position of slider ○ out
	Analyzer Slot	Rotatable Analyzer with Slot (U-AN360P-2)
Analyzer (U-AN360P-2)	360° Dial-Rotatable Rotatable Minimum Angle 0.1°	
Revolving Centerable Nosepiece (U-P4RE)	Quadruple, centerable attachable components: 1/4 wavelength retardation plate (U-TAD), tint plate (U-TP530) and various compensators can be attached using plate adapter (U-TAD).	
Stage (U-SRP)	Polarizing rotatable stage with 3-point centering function. 360° rotatable, lockable in any position, 360° graduated in 1° increments (minimum retardation resolution 6', using vernier scale). 45° click stop function. ● Slide holder (U-SCB2) and mechanical stage (U-FMP) can be attached.	
Condenser (U-POC-2)	Achromat strain-free condenser (U-POC-2), 360° rotatable polarizer with swing-out achromatic top-lens, Click stop at position "0°" is adjustable. NA 0.9 (top-lens in) NA 0.18 (top-lens out) Aperture iris diaphragm: adjustable from 2 mm to 21 mm diameters.	

- OLYMPUS CORPORATION is ISO14001 certified.
- OLYMPUS CORPORATION is FM553994/ISO9001 certified.
- Illumination devices for microscope have suggested lifetimes. Periodic inspections are required. Please visit our website for details.

- All company and product names are registered trademarks and/or trademarks of their respective owners.
- Specifications and appearances are subject to change without any notice or obligation on the part of the manufacturer.

www.olympus-lifescience.com

OLYMPUS[®]

For enquiries - contact
www.olympus-lifescience.com/contact-us

OLYMPUS CORPORATION
Shinjuku Monolith, 2-3-1 Nishi-Shinjuku, Shinjuku-ku, Tokyo 163-0914, Japan

OLYMPUS EUROPA SE & CO. KG
Wendenstrasse 14-18, 20097 Hamburg, Germany

OLYMPUS SCIENTIFIC SOLUTIONS AMERICAS CORP.
48 Woerd Avenue, Waltham, MA 02453, U.S.A.

OLYMPUS SINGAPORE PTE LTD.
491B River Valley Road, #12-01/04 Valley Point Office Tower, Singapore 248373

OLYMPUS AUSTRALIA PTY. LTD.
3 Acacia Place, Notting Hill VIC 3168, Australia

OLYMPUS LATIN AMERICA, INC.

5301 Blue Lagoon Drive, Suite 290 Miami, FL 33126, U.S.A.

OLYMPUS (CHINA) CO., LTD.

A8F, Ping An International Financial Center, No. 1-3, Xinyuan South Road, Chaoyang District, Beijing, 100027 P.R.C.

OLYMPUS KOREA CO., LTD.

8F Olympus Tower, 446 Bongeunsa-ro, Gangnam-gu, Seoul, 135-509 Korea